

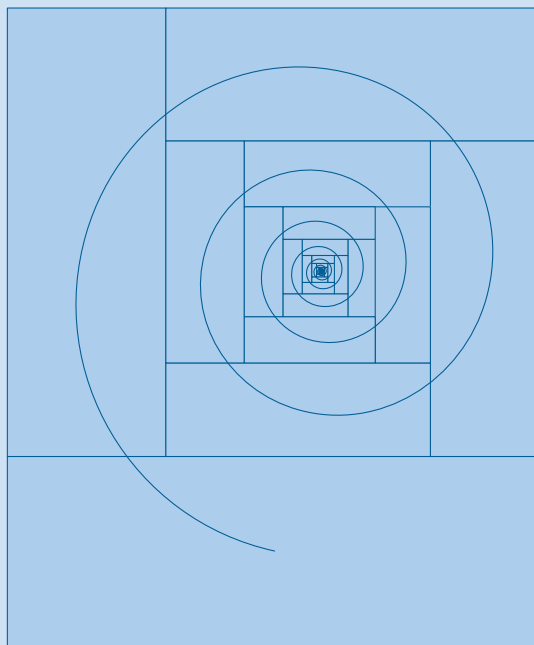

TEX Gyre: The New Font Project



Marrakech, November 9th–11th, 2006

Bogusław Jackowski, Janusz M. Nowacki, Jerzy B. Ludwichowski

What is the T_EX Gyre project about?

What is the T_EX Gyre project about?

It is, in a way, a continuation of two LUG projects: one already accomplished and the other currently suspended.

What is the T_EX Gyre project about?

It is, in a way, a continuation of two LUG projects: one already accomplished and the other currently suspended.

The former is the Latin Modern family of fonts, i.e., a collection of 92 fonts (72 text and 20 math ones) in the POSTSCRIPT Type 1 and OTF formats, based on the Computer Modern fonts, equipped with a rich repertoire of diacritical characters.

What is the T_EX Gyre project about?

It is, in a way, a continuation of two LUG projects: one already accomplished and the other currently suspended.

The former is the Latin Modern family of fonts.

The latter is a GUST project, launched in 1996, aimed at supplementing Adobe's 35 basic fonts with a rich repertoire of diacritical characters (the working name was *Qfonts*).

What is the T_EX Gyre project about?

It is, in a way, a continuation of two LUG projects: one already accomplished and the other currently suspended.

The former is the Latin Modern family of fonts.

The latter is a GUST project, launched in 1996, aimed at supplementing Adobe's 35 basic fonts with a rich repertoire of diacritical characters.

licence: the GUST Font License
(open, legally LPPL)

maintainers: B. Jackowski and J. M. Nowacki, GUST

The fame of the names

The fame of the names

The source for the work will be the available openware fonts, most notably the collection released by URW++ and distributed with Ghostscript.

The fame of the names

The source for the work will be the available openware fonts, most notably the collection released by URW++ and distributed with Ghostscript.

Unfortunately, the original Adobe names cannot be retained due to copyrights and registered trademarks issues. URW names, on the other hand, are somewhat incongruous. Therefore we decided to coin new names, mnemonic to some extent, consistent within the project.

The fame of the names

The source for the work will be the available openware fonts, most notably the collection released by URW++ and distributed with Ghostscript.

Unfortunately, the original Adobe names cannot be retained due to copyrights and registered trademarks issues. URW names, on the other hand, are somewhat incongruous. Therefore we decided to coin new names, mnemonic to some extent, consistent within the project.

It is intended that all GUST Qfonts fonts will eventually be replaced by the T_EX Gyre fonts, preferably in a transparent way.

The names of the game

Origin	PS name	TFM name (kernel)
ITC Avant Garde Gothic	TeXGyreAdventor	qag
ITC Bookman	TeXGyreBonum	qbk
Courier	TeXGyreCursor	qcr
Helvetica	TeXGyreHeros	qhv
Palatino	TeXGyrePagella	qpl
Times	TeXGyreTermes	qtm
New Century Schoolbook	TeXGyreSchola	qcs
ITC Zapf Chancery	TeXGyreChorus	qzc

The names of the game

Origin	OTF name
ITC Avant Garde Gothic	TeX Gyre Adventor
ITC Bookman	TeX Gyre Bonum
Courier	TeX Gyre Cursor
Helvetica	TeX Gyre Heros
Palatino	TeX Gyre Pagella
Times	TeX Gyre Termes
New Century Schoolbook	TeX Gyre Schola
ITC Zapf Chancery	TeX Gyre Chorus

Font species: T_EX Gyre Bonum (v. 0.995)

TAŃÓHąmburğefónśź 0123456789

TAŃÓHąMBURğEFÓNŚŹ 0123456789

TAŃÓHąmburğefónśź 0123456789

TAŃÓHąMBURğEFÓNŚŹ 0123456789

TAŃÓHąmburğefónśź 0123456789

TAŃÓHąMBURğEFÓNŚŹ 0123456789

TAŃÓHąmburğefónśź 0123456789

TAŃÓHąMBURğEFÓNŚŹ 0123456789

Font species: T_EX Gyre Pagella (v. 1.000)

TĄÓHąmburğefónśź 0123456789

TĄÓHĄMBURĞEFÓNŚŹ 0123456789

TĄÓHąmburğefónśź 0123456789

TĄÓHĄMBURĞEFÓNŚŹ 0123456789

TĄÓHąmburğefónśź 0123456789

TĄÓHĄMBURĞEFÓNŚŹ 0123456789

TĄÓHąmburğefónśź 0123456789

TĄÓHĄMBURĞEFÓNŚŹ 0123456789

Font species: T_EX Gyre Termes (v. 1.000)

TAÓHąmburğefónśź 0123456789

TAÓHąMBURGEFÓNŚŹ 0123456789

TAÓHąmburğefónśź 0123456789

TAÓHąMBURGEFÓNŚŹ 0123456789

TAÓHąmburğefónśź 0123456789

TAÓHąMBURGEFÓNŚŹ 0123456789

TAÓHąmburğefónśź 0123456789

TAÓHąMBURGEFÓNŚŹ 0123456789

TeX Gyre: the repertoire of glyphs

°C ^ ^ ^ ^ ^ ^ ^ ^ ^ ^ ^ ^ : Ç , , © © □ D d D
 † ‡ đ ||] ^ " || Đ đ đ Đ đ Đ ° Δ δ Ø † ... %
 ÷ o | o đ \$ \$ đ · · ı ı j j d' E e E É é É Ě ě Ě Ě
 ě ě Ê ê Ê Ě ě Ě Ě ě ě Ě ě ě Ě ě ě Ě ě ě
 Ě ě Ě Ě ě ě Ě ě Ě Ě ě ě Ě ě ě 8 8 8 8 l ... E ē
 ē — — N n N E e E E e e E e e E e e E e e €
 ! ; F f F f k f f f i f f l f i 5 5 5 5 f l f 4 4 4 4 //
 G g G G g g G g g G g g G g g G g g G g g G
 g g S S ß ß s s ; ` ` > ≥ ≳ G « » ‹ › H h H H
 ħ H H H h h H h h H h h H h h H h h H h h
 î Ì ì ì Ì ì ì Í í í İ ĩ İ İ İ İ İ İ İ İ İ İ İ İ İ İ İ
 İ
 Í
 Í
 Í

TeX Gyre: the repertoire of glyphs

˘ ˙ ˚ ˛ ˜ ˝ ƒ ™ — ² ² ² ² ² U u u Ú ú ú Ũ
Û ü Ů ů Ű ű Ų ų Ŵ ŵ Ŷ ŷ Ÿ Ź ź ź Ż
Ù ù Ú ú Ū ū Ŵ ŵ Ŷ ŷ Ÿ Ź ź ź Ż
Ŵ ŵ Ŷ ŷ Ÿ Ź ź ź Ż È Ë è ë Ъ ъ Р р
Г г Ж ж З з К к К к К к Н н Н
н П п С с С с Т т У у У у Х х Ц ц Ч ч
Ч ч Ъ ъ С с С с І Ж ж К к Н н Ч ч Ǻ
ǻ Ǽ æ Ě ě Э Э э Ж ж З з Ȫ ȫ Ȭ ȭ
Ȯ ȯ Ө ө Ө ө Э э Ȫ ȫ Ȭ ȭ Ȯ ȯ Ъ ъ
У у Ȫ ȫ Ȭ ȭ Ȯ ȯ V v v □ W w w Ẁ
ẁ Ẃ ẃ Ẅ ẅ Ẇ ẇ Ẉ ẉ X x x Ξ Υ
ϒ ϓ Ȫ ȫ Ȭ ȭ Ȯ ȯ Ȫ ȫ Ȭ ȭ Ȯ ȯ
Ȫ ȫ Ȭ ȭ Ȯ ȯ Z z z Ẁ ẁ Ẃ ẃ Ẅ ẅ Ẇ ẇ Ẉ ẉ 0 0 0 0

The T_EX Gyre fonts are available from:

<http://www.gust.org.pl/projects/e-foundry/tex-gyre>

<http://www.gust.org.pl/e-foundry/tex-gyre>

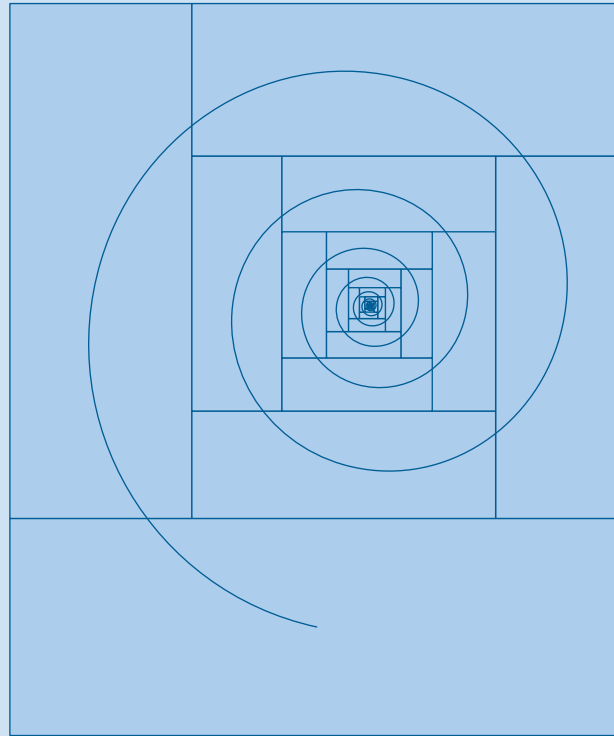

The *T_EX Gyre* project is supported by T_EX Users Groups, in particular, by the Czechoslovak T_EX Users Group CSTUG, the German-speaking T_EX Users Group DANTE e.V., the Polish T_EX Users Group GUST, the Dutch-speaking T_EX Users Group NTG, TUG India, and—last but not least—TUG.